

(as of October 3, 2014)



Manufacturer : Piaggio Aero Industries S.p.A.

Model : P.180 Avanti II

Serial Number :

Registration :

First Delivery : April 2008

Airframe (*) : 510 Flight Hours Total Time

Engines (*) : Pratt & Whitney Canada PT6A-66B

LH: 510 TSNEW S/N PCE-RW

RH: 510 TSNEW S/N PCE-RW

Propellers (*) : Hartzell HC-E5N-3A/AL

LH: 510 TSNEW S/N KU-

RH: 510 TSNEW S/N HF-

Additional Features :

- Satellite Phone Air Cell ST3100 with two handsets
- Upgrade for Integrated Flight Information Collins IFIS 5000
- Electronic Charts Collins ECH 5000
- Maps Overlay Collins OVL 5000
- VIP Interiors with 6 seats (Option 2)
- Toilette with Vanity Module including sink with water faucet
- Gravel Kit

(*) as of October 3, 2014

(as of October 3, 2014)

Avionics:Collins Pro-Line 21 - UPGRADE IFIS 5000

- ❑ Radio Management System – Collins RTU-4200, CDU-3000
- ❑ Dual VHF COM - Collins VHF-4000 Transceiver with Antenna with 8.33 kHz spacing
- ❑ VHF NAV 1 + ADF - Collins NAV-4000 VOR/ILS/MKR/ADF Receiver with Antennae
- ❑ VHF NAV 2 - Collins NAV-4500 VOR/ILS/MKR Receiver with Antennae
- ❑ Single DME - Collins DME-4000 (3 channel) with Antenna
- ❑ Dual Mode S Flight ID Diversity Transponder - Collins TDR-94D
- ❑ Radio Altimeter - Collins ALT-4000 (Operation to 2500 ft) with Antennae
- ❑ Turbulence Detection Weather Radar - Collins RTA-852 Colour Radar with 12" Antenna
- ❑ TAWS Class B with Worldwide Database – L-3 Landmark TAWS 8000
- ❑ Dual Audio Panel - Baker B1045
- ❑ Dual Cockpit Speaker
- ❑ Dual hand-held Microphone
- ❑ Dual Boom/Microphone/Headset
- ❑ EFIS with EIS – Three Collins displays AFD-3010, two DCP-3030, CCP-3000
- ❑ Flight Guidance System - Collins Dual FGC-3003 (A/P,YD and dual Flight Director included),three SVO-3000 Servos, single FGP-3000 Flight Guidance Panel
- ❑ Single FMS - Collins FMC-3000 (NAV to NAV and VNAV), CDU-3000 (used also for radio tuning),
- ❑ DBU-4100
- ❑ GPS Sensor Unit - Collins GPS-4000A
- ❑ Dual ADS - Collins ADC-3000
- ❑ Dual AHRS - Collins AHC-3000 and FDU-3000
- ❑ Maintenance Diagnostic System - Collins MDC-3110
- ❑ Four Data Concentrator Unit - Collins DCU-3001
- ❑ Stand-by Cluster Instrument – L-3 Communications GH-3100
- ❑ Emergency Locator Transmitter – Techtest Model 503 (3 frequency)
- ❑ Dual Clock (Flight Hour Meter included)
- ❑ Dual Master Annunciator
- ❑ Dual Turn & Slip Indicator (shown on the displays)
- ❑ Reversionary/Miscellaneous Panel
- ❑ RVSM Compliant



(as of October 3, 2014)

Optional Equipment:

- Satellite Phone Air Cell ST3100 with two handsets
- Upgrade for Integrated Flight Information Collins IFIS 5000
- Electronic Charts Collins ECH 5000
- Maps Overlay Collins OVL 5000
- VIP – 6 Seats Cabin Arrangement (Option 2)
- Toilette with Vanity Module including sink with water faucet
- Gravel Kit
- Sheep Skin for Pilot & Co-pilot Seats

Interior: VIP Corporate Interiors - Option 2 floorplan (6 seats)

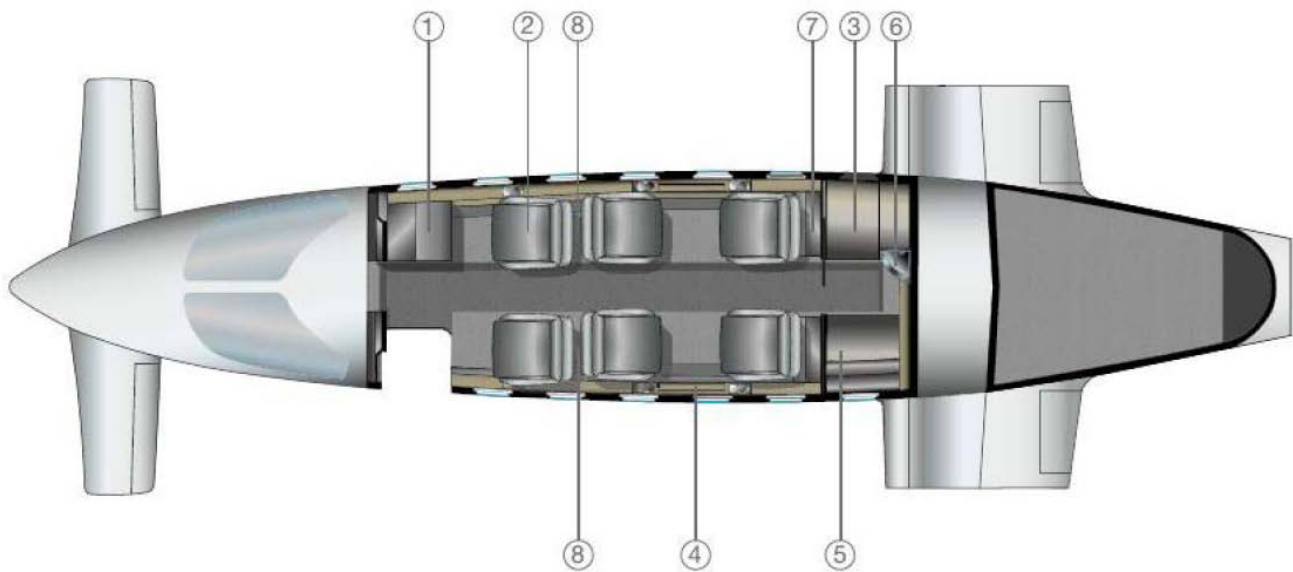

1. Refreshment cabinet with annex (optional)
2. Single seat
3. Storage closet
4. Fold out executive table
5. Belted toilet seat
6. Optional sink
7. RH pyramid cabinet (optional)
8. Mid-ship pyramid cabinet

- Six single passenger seats in club arrangement
- Aft fully enclosed lavatory with flushing potty and belted aft auxiliary passenger seat and coat closet.
- Toilette with Vanity Module including sink with water faucet
- Dual executive tables
- Pyramid with ice chest and miscellaneous storage
- Beige Leather with "Carbon-fiber" trimming

(as of October 3, 2014)



(as of October 3, 2014)



(as of October 3, 2014)

Exterior: Overall white with light blue and red accent stripes

