

(as of December 1, 2014)



Manufacturer : Piaggio Aero Industries S.p.A.

Model : P.180 Avanti II

Serial Number : 1225

First Delivery : July 2012

Airframe (*) : 772 Flight hrs. Total Time - 746 Landings

Engines (*) : Pratt & Whitney Canada PT6A-66B
 LH: 772 TSNEW S/N PCE-RW0196
 RH: 772 TSNEW S/N PCE-RW0191

Propellers (*) : Hartzell HC-E5N-3A/AL
 LH: 772 TSNEW S/N KU-208
 RH: 772 TSNEW S/N HF-344

Additional Features :

- Fresh of B-Check
- Satellite Phone Air Cell ST3100 with two handsets
- Upgrade for Integrated Flight Information Collins IFIS 5000
- Electronic Charts Collins ECH 5000
- Maps Overlay Collins OVL 5000
- TCAS II
- ADAS - ENGINE DATA ACQUISITION & MONITORING SYSTEM
- JAR-OPS 1 Kit
- Max Take Off Weight Increase (12,100 lbs)
- VIP Interiors with 6 seats (Option 2)

(*) as of December 1, 2014

(as of December 1, 2014)

Avionics: Collins Pro-Line 21 - UPGRADE IFIS 5000

- ❑ Radio Management System – Collins RTU-4200, CDU-3000
- ❑ Dual VHF COM - Collins VHF-4000 Transceiver with Antenna with 8.33 kHz spacing
- ❑ VHF NAV 1 + ADF - Collins NAV-4000 VOR/ILS/MKR/ADF Receiver with Antennae
- ❑ VHF NAV 2 - Collins NAV-4500 VOR/ILS/MKR Receiver with Antennae
- ❑ Single DME - Collins DME-4000 (3 channel) with Antenna
- ❑ Dual Mode S Flight ID Diversity Transponder - Collins TDR-94D
- ❑ Radio Altimeter - Collins ALT-4000 (Operation to 2500 ft) with Antennae
- ❑ Turbulence Detection Weather Radar - Collins RTA-852 Colour Radar with 12" Antenna
- ❑ TCAS II - Collins TCAS-4000 system
- ❑ TAWS Class B with Worldwide Database – L-3 Landmark TAWS 8000
- ❑ Dual Audio Panel - Baker B1045
- ❑ Dual Cockpit Speaker
- ❑ Dual hand-held Microphone
- ❑ Dual Boom/Microphone/Headset
- ❑ EFIS with EIS – Three Collins displays AFD-3010, two DCP-3030, CCP-3000
- ❑ Flight Guidance System - Collins Dual FGC-3003 (A/P,YD and dual Flight Director included),three SVO-3000 Servos, single FGP-3000 Flight Guidance Panel
- ❑ Single FMS - Collins FMC-3000 (NAV to NAV and VNAV), CDU-3000 (used also for radio tuning),
- ❑ DBU-4100
- ❑ GPS Sensor Unit - Collins GPS-4000A
- ❑ Dual ADS - Collins ADC-3000
- ❑ Dual AHRS - Collins AHC-3000 and FDU-3000
- ❑ Maintenance Diagnostic System - Collins MDC-3110
- ❑ Four Data Concentrator Unit - Collins DCU-3001
- ❑ Stand-by Cluster Instrument – L-3 Communications GH-3100
- ❑ Emergency Locator Transmitter – Techtest Model 503 (3 frequency)
- ❑ Dual Clock (Flight Hour Meter included)
- ❑ Dual Master Annunciator
- ❑ Dual Turn&Slip Indicator (shown on the displays)
- ❑ Reversionary/Miscellaneous Panel
- ❑ RVSM Compliant



(as of December 1, 2014)

Optional Equipment:

- Satellite Phone Air Cell ST3100 with two handsets
- Upgrade for Integrated Flight Information Collins IFIS 5000
- Electronic Charts Collins ECH 5000
- Maps Overlay Collins OVL 5000
- TCAS II
- ADAS
- Engine Fire Extinguisher
- JAR-OPS 1 Kit
- Max Take Off Weight Increase (12,100 lbs)
- VIP – 6 Seats Cabin Arrangement (Option 2)
- Sheep Skin for Pilot & Co-pilot Seats

Interior: VIP Corporate Interiors - Option 2 floorplan (6 seats)

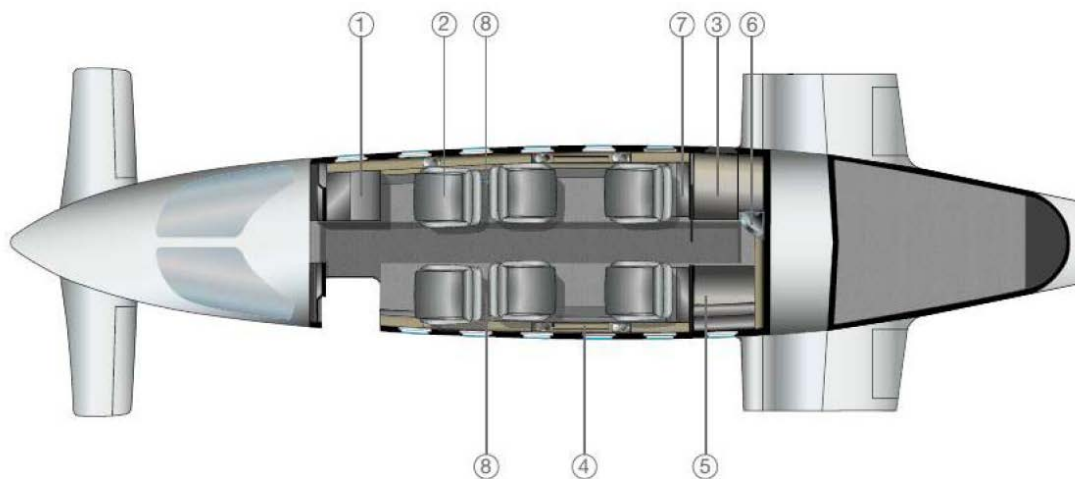

1. Refreshment cabinet with annex (optional)
2. Single seat
3. Storage closet
4. Fold out executive table
5. Belted toilet seat
6. Optional sink
7. RH pyramid cabinet (optional)
8. Mid-ship pyramid cabinet

- Six single passenger seats in club arrangement
- Aft fully enclosed lavatory with flushing potty and belted aft auxiliary passenger seat and coat closet.
- Dual executive tables
- Pyramid with ice chest and miscellaneous storage
- Red Leather upholstery
- 110 VAC power outlets in cockpit and passenger cabin

(as of December 1, 2014)



(as of December 1, 2014)

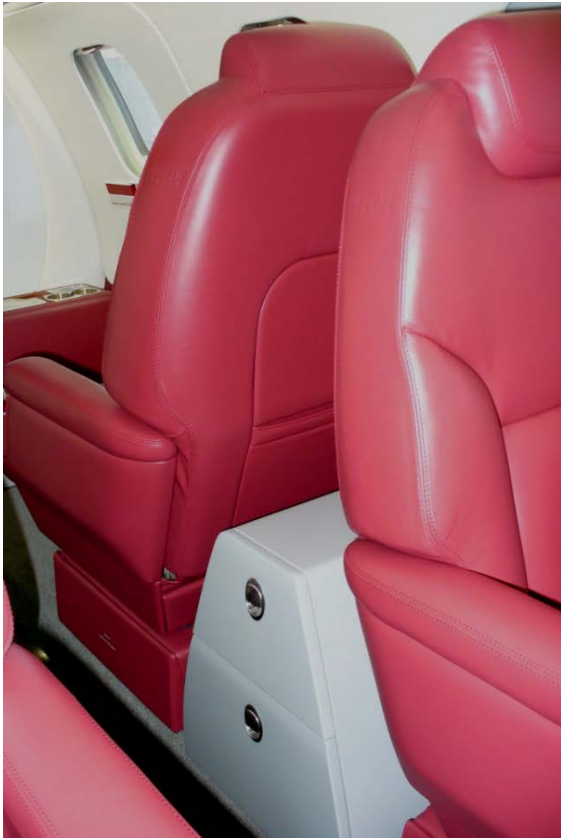

SPECIFICATIONS AND/OR DESCRIPTIONS ARE PROVIDED AS INTRODUCTORY INFORMATION ONLY AND DO NOT CONSTITUTE REPRESENTATIONS OR WARRANTIES OF ORIONFLY. VERIFICATION OF SPECIFICATIONS REMAINS SOLE RESPONSIBILITY OF PURCHASER. AIRCRAFT SUBJECT TO PRIOR SALE AND REMOVAL FROM THE MARKET.

(as of December 1, 2014)

Exterior: Overall metal grey



Aviation Consultancy and Aircraft Sales



Exclusive Sales Representative
North Africa and Central Asia

MASSIMO ISIDORI

Orion Fly s.r.l.

via Palermo, 13
63015 Monte Urano (AP) ITALY

phone +39.0734.841452

fax +39.0734.840776

mobile +39.335.7367145

P.IVA 01202760448

www.orionfly.it - massimo@orionfly.it